

HYBRID SYSTEMS FOR CONVERTING RENEWABLE ENERGY OF SMALL VOLTAGE, INTEGRATED INTO A MICRO-NETWORK

Goal of the project

The project is focused on the research, development and testing of an intelligent and flexible (configurable) small scale power system based on integration of three renewable energy sources: wind, hydro, and solar (photovoltaic) power, adapted to the available resources in Romania, in various regions of the country, working independently or connected to the grid.

Short description of the project

The project will cover the entire power conversion structure, including the design of adequate prime movers and new types of generators and power electronic converters, storage devices, power flow management system and load control. Some configurable structures (wind, micro-hydro and PV, all or a part of them, including their integration in a microgrid) will be proposed as experimental models, ready to be transferred to industry. There are proposed novelty elements regarding: low power wind turbine with integrated overspeed protection system, new generators configurations, and new topologies for power electronic converters and microgrid structures, optimal local control strategies and intelligent power system management.

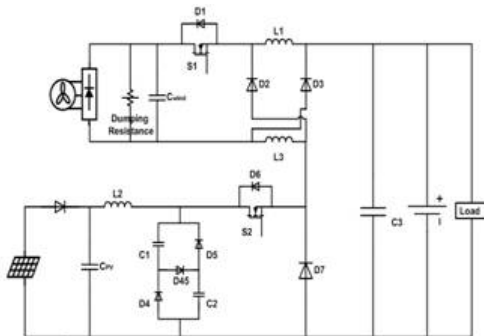

Main activities

- Microgrid components modeling, simulation and design.
- Microgrid components manufacturing, individual testing and integration in the experimental setup.
- Design, implementation and validation of the control strategies for microgrid components.
- Design, implementation and validation of the microgrid control strategy.
- Results dissemination and know-how exchange.

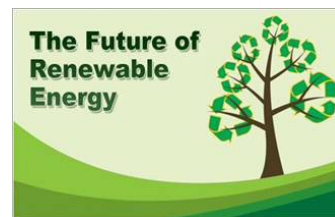

Results

- A new over-speed protection system for wind turbines.
- A new electrical reactive brushless dc generator with performances comparable with high energy PM generator, at low cost.
- A new RF-IPMSG with high efficiency, maintenance-free operation, and high-controllability.
- A new AF-PMSG optimised for modular design. A new multiphase inverter with adequate control for the proposed generators.
- New multi-input dc-dc converters with high efficiency.
- High power tandem inverters for load management.
- Hardware and software package for power management, power flow control, individual converter control, and MPPT and other control strategies.
- Experimental microgrid system with integrated photovoltaic, wind and hydro generation.
- Technical papers will be published in top international journals and conference proceedings.

Research centre

Research Centre for Automatic Systems Engineering

Project implemented by

Politehnica University of Timisoara – Project coordinator
 Technical University of Cluj-Napoca – Project partner
 SC EETIM SA – Project partner

Implementation period

2012-2015

Applicability and transferability of the results

All the research results are the property of the project coordinator and its partners.

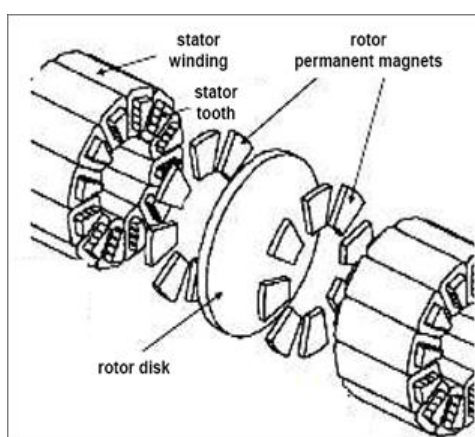

Financed through/by

Joint Applied Research Projects - Partnership in S&T priority domains financed by the Executive Agency for Higher Education, Research, Development and Innovation Funding (UEFISCDI).



Research team

UPT:
Octavian PROSTEAN
Nicolae MUNTEAN
Nicolae BUDISAN
Ioan FILIP
Mircea BARGLAZAN,
Gabriela PROSTEAN
Stefan KILYENI
Ilarie BORDEASU
Teodor MILOS
Cristian VASAR
Lucian TUTELEA
Cristian LASCU
Sorin DEACONU
Dan UNGUREANU
Iosif SZEIDERT
Adrian BEJ
Radu BORACI
Octavian CORNEA
Ovidiu TIRIAN
Rodica BADARAU .

Contact information

Prof. Octavian PROSTEAN, PhD
Department of Automation and Applied Informatics
Address: Bv. Vasile Pârvan, No. 2, RO300223, Timisoara
Phone: (+40) 256 403 225
Fax: (+40) 256 403 214
E-mail: octavian.prostean@upt.ro